



Title : Goalie Game Situation Drill 5

Category : Age 10 to 20

Content : Wrap around + Screen situation

Drill description :

- 1) The goalie has a series of movements to do before he faces the first shot.
- 2) Shooter 1 will need to wait for the goalie to go behind the net and then go for a wrap around when the goalie is ready for him. (no rebound)
- 3) Shooter 1 will go in front of the goalie after the shot is taken to create a screen.
- 4) Shooter 2 will choose a shooting lane to get a good screen shot.
- 5) Shooter 1 or 2 can take the rebound on the last shot.

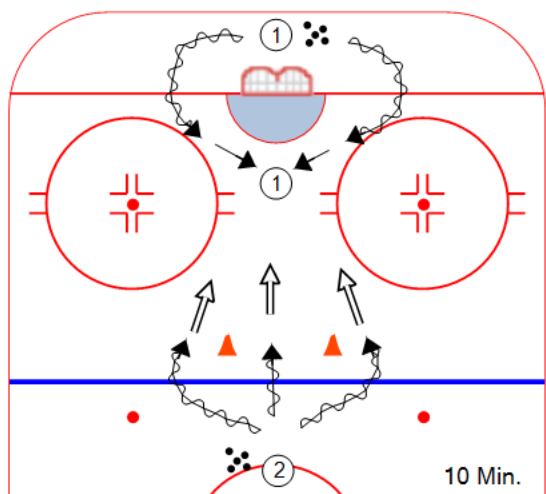

Key points

- Be patient
- Challenge the shooter
- Square to the puck
- Track the puck

Goalie movements

- 1- T-push
- 2- Butterfly
- 3- Recovery T-push to the post
- 4- _____
- 5- _____
- 6- _____
- 7- _____
- 8- _____
- 9- _____
- 10- _____

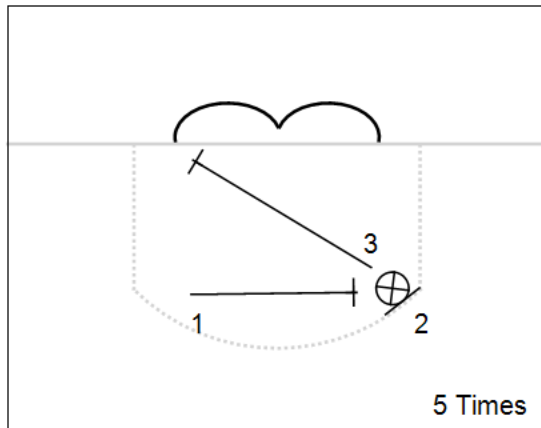

Notes

Symbols legend :

	Basic position		Butterfly
	Post positioning (left)		Vertical - Horizontal
	Half-butterfly (left)		Jump
	Dive		180 rotation
	360 rotation		Roll
	"C" cut		Power Push
	Slide		"T" push
	2 pad stack		Butterfly slide
	Shuffle		1/2 butterfly slide

